

Features

- 9-Set Voltage Monitors (4 Fixed Inputs for 7.0V, 4.5V, 4.0V and 3.0V, 5 Adjustable Inputs with 1.5V Internal Reference)
- Input Voltage Range of 2~5V (Good for RTC Battery)
- Complementary Output to Drive 2N7002
- Outputs with Latch
- Quiescent Supply Current : 40μA
- Quiescent Supply Current : 30μA When Output Latch
- $V_{REF}=1.5V\pm 2.0\%$ Over Temp

Applications

- Note Book Computer
- Multiple Supply System

Pin Configuration

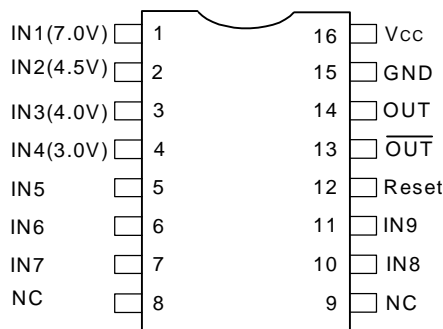

APX1690 (QSOP -16)

General Description

The APX1690 is a precise 9-Set over voltage protector. The trigger voltages of IN1 to IN4 are internally set to detect the 7.0V, 4.5V, 4.0V and 3.0V, respectively. The trigger voltage of IN5 to IN9 can be set by using external resistor divider with the internal reference voltage (1.5V). The APX1690 offers 2% voltage setting accuracy over temp, and an ultra low ground current 40μA(max). The ground current is reduced to 30μA(max) when an over voltage happened and output is latched. Both complementary outputs (OUT and \overline{OUT}) are latched when an over voltage is detected in either input. An external active high on reset pin can be used to reset the latch. A compact package QSOP-16 is available for space saving purpose.

ANPEC reserves the right to make changes to improve reliability or manufacturability without notice, and advise customers to obtain the latest version of relevant information to verify before placing orders.

Ordering and Marking Information

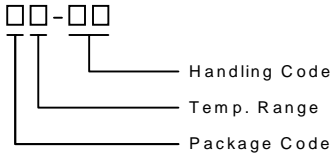
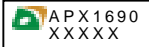
<p>APX1690</p> 	<p>Package Code M : QSOP - 16 Temp. Range E : -20 to 70 °C Handling Code TU : Tube TR : Tape & Reel</p>
<p>APX1690 N :</p> 	<p>XXXXX - Date Code</p>

Pin Description

PIN		I/O	Description
No.	Name		
1	IN1	I	Input pin for 7.0V detection
2	IN2	I	Input pin for 4.5V detection
3	IN3	I	Input pin for 4.0V detection
4	IN4	I	Input pin for 3.0V detection
5	IN5	I	Input pin for 1.5V detection
6	IN6	I	Input pin for 1.5V detection
7	IN7	I	Input pin for 1.5V detection
8,9	NC		
10	IN8	I	Input pin for 1.5V detection
11	IN9	I	Input pin for 1.5V detection
12	Reset	I	Input pin of reset signal (active high)
13	$\overline{\text{OUT}}$	O	Output low signal when latched
14	OUT	O	Output high signal when latched
15	GND	O	Ground pin for signal and power ground
16	V _{cc}	I	Input pin of supply voltage

Block Diagram

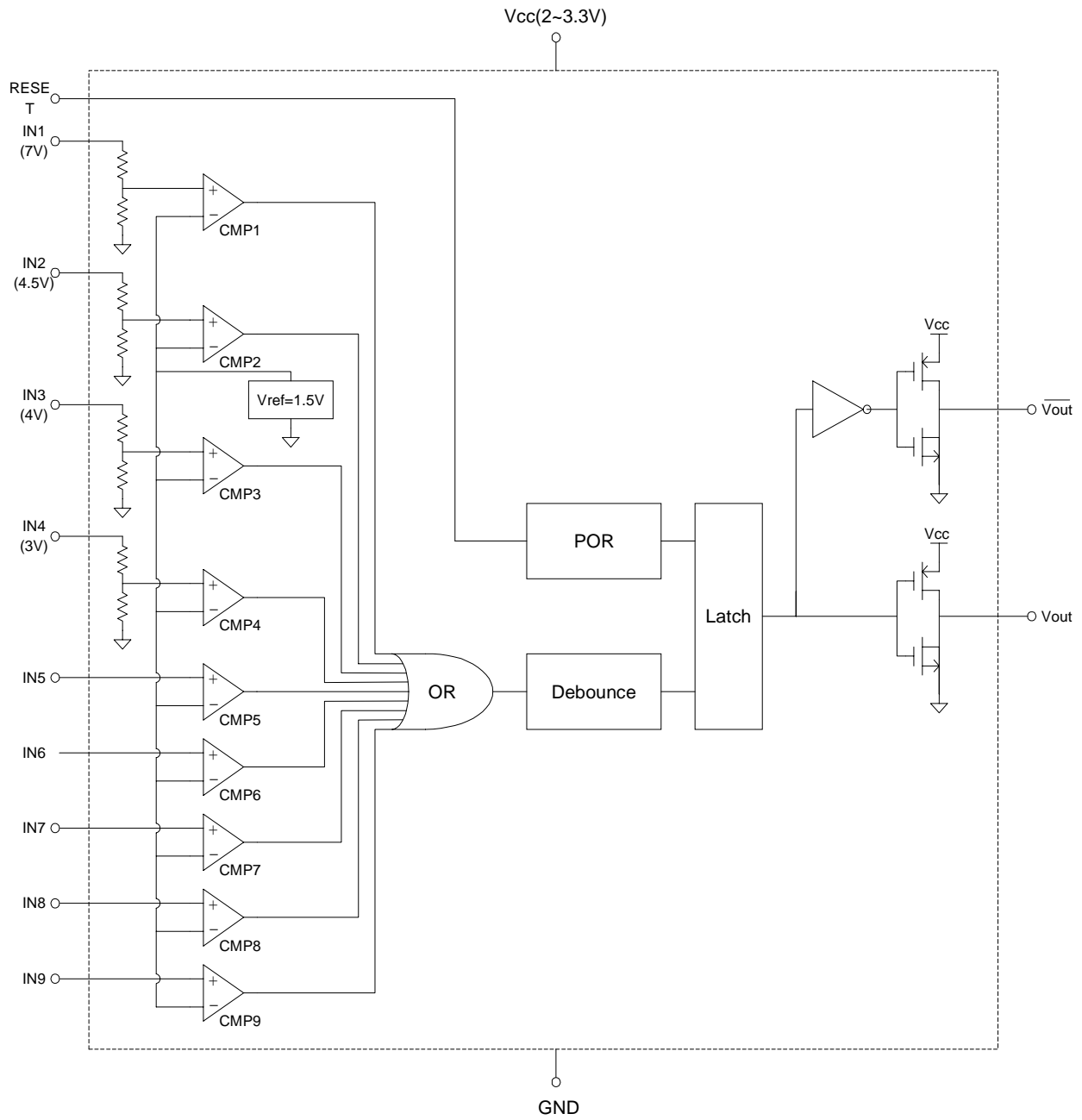

Absolute Maximum Ratings

Symbol	Parameter	Rating	Unit
V _{CC}	Input Voltage	7	V
IN1~IN9, Reset	All Input Pins	7	V
T _J	Operating Junction Temperature	-20 to 150	°C
T _{STG}	Storage Temperature	-65 to +150	°C
T _S	Soldering Temperature (10 seconds)	260	°C
ESD	ESD Classification	2	kV

Electrical Characteristics

T_A=25°C, V_{CC}=3V unless otherwise specified.

Symbol	Parameter	Test Conditions	APX1690			Unit
			Min.	Typ.	Max.	
V _{CC}	Supply Voltage		2		5	V
I _{CC}	Supply Current				40	μA
V _{REF}	Internal Reference Voltage	0~125°C	1.477	1.500	1.523	V
t	Debounce Time		100			μS
I _{DRIVE}	Output Drive Current	C _{OUT} =1nF	5			mA
I _{SINK}	Output Sink Current	C _{OUT} =1nF	5			mA
I _{LATCH}	Supply Current when Latch				30	μA
V _{T1}	Tripped Voltage of IN1			7±2%		V
V _{T2}	Tripped Voltage of IN2			4.5±2%		V
V _{T3}	Tripped Voltage of IN3			4±2%		V
V _{T4}	Tripped Voltage of IN4			3±2%		
V _{T5}	Tripped Voltage of IN5			V _{REF}		
V _{T6}	Tripped Voltage of IN6			V _{REF}		
V _{T7}	Tripped Voltage of IN7			V _{REF}		
V _{T8}	Tripped Voltage of IN8			V _{REF}		
V _{T9}	Tripped Voltage of IN9			V _{REF}		
Reset	Reset Input Signal (Active High)			0.5*V _{CC}		

Package Information

QSOP-16

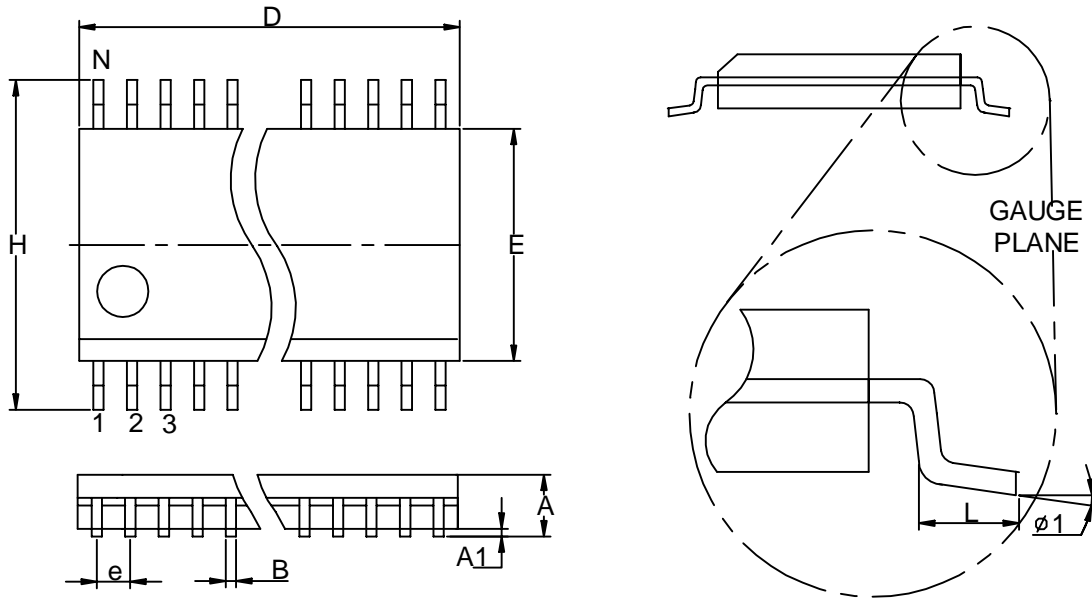

Dim	Millimeters		Variations- D			Dim	Inches		Variations- D		
	Min.	Max.	Variations	Min.	Max.		Min.	Max.	Variations	Min.	Max.
A	1.350	1.75	QSOP-16	4.75	5.05	A	0.053	0.069	QSOP-16	0.187	0.199
A1	0.10	0.25				A1	0.004	0.010			
B	0.20	0.30				B	0.008	0.012			
D	See variations					D	See variations				
E	3.75	4.05				E	0.147	0.160			
e	0.625 TYP.					e	0.025 TYP.				
H	5.75	6.25				H	0.226	0.246			
L	0.4	1.27				L	0.016	0.050			
N	See variations					N	See variations				
$\phi 1$	0°	8°				$\phi 1$	0°	8°			

Physical Specifications

Terminal Material	Solder-Plated Copper (Solder Material : 90/10 or 63/37 SnPb)
Lead Solderability	Meets EIA Specification RSI86-91, ANSI/J-STD-002 Category 3.

Reflow Condition (IR/Convection or VPR Reflow)

Reference JEDEC Standard J-STD-020A APRIL 1999

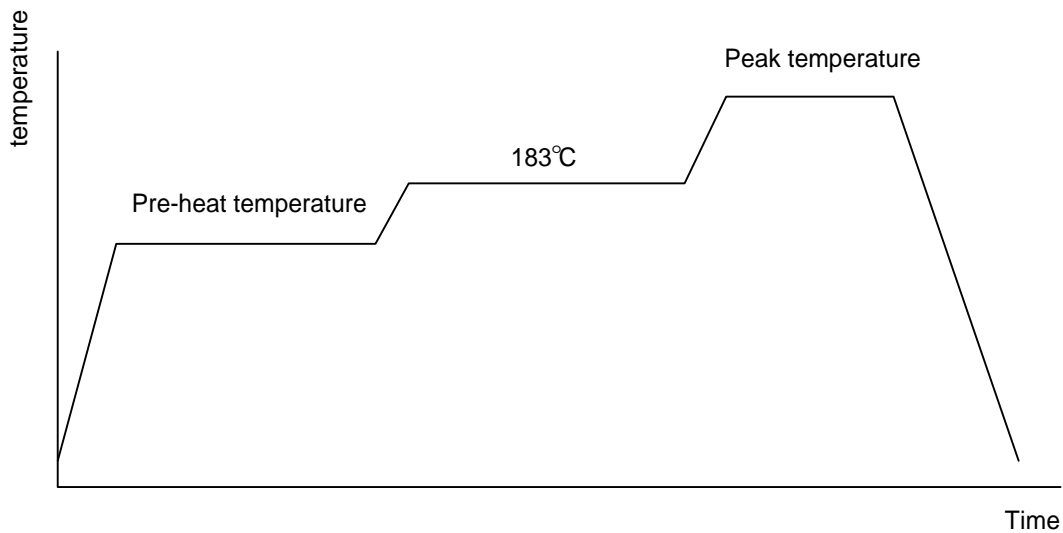

Classification Reflow Profiles

	Convection or IR/ Convection	VPR
Average ramp-up rate(183°C to Peak)	3°C/second max.	10 °C /second max.
Preheat temperature 125 ± 25°C)	120 seconds max	
Temperature maintained above 183°C	60 – 150 seconds	
Time within 5°C of actual peak temperature	10 –20 seconds	60 seconds
Peak temperature range	220 +5/-0°C or 235 +5/-0°C	215-219°C or 235 +5/-0°C
Ramp-down rate	6 °C /second max.	10 °C /second max.
Time 25°C to peak temperature	6 minutes max.	

Package Reflow Conditions

pkg. thickness ≥ 2.5mm and all bgas	pkg. thickness < 2.5mm and pkg. volume ≥ 350 mm ³	pkg. thickness < 2.5mm and pkg. volume < 350mm ³
Convection 220 +5/-0 °C		Convection 235 +5/-0 °C
VPR 215-219 °C		VPR 235 +5/-0 °C
IR/Convection 220 +5/-0 °C		IR/Convection 235 +5/-0 °C

Reliability test program

Test item	Method	Description
SOLDERABILITY	MIL-STD-883D-2003	245°C , 5 SEC
HOLT	MIL-STD-883D-1005.7	1000 Hrs Bias @ 125 °C
PCT	JESD-22-B, A102	168 Hrs, 100 % RH , 121°C
TST	MIL-STD-883D-1011.9	-65°C ~ 150°C, 200 Cycles
ESD	MIL-STD-883D-3015.7	VHBM > 2KV, VMM > 200V
Latch-Up	JESD 78	10ms , I _{tr} > 100mA

Carrier Tape

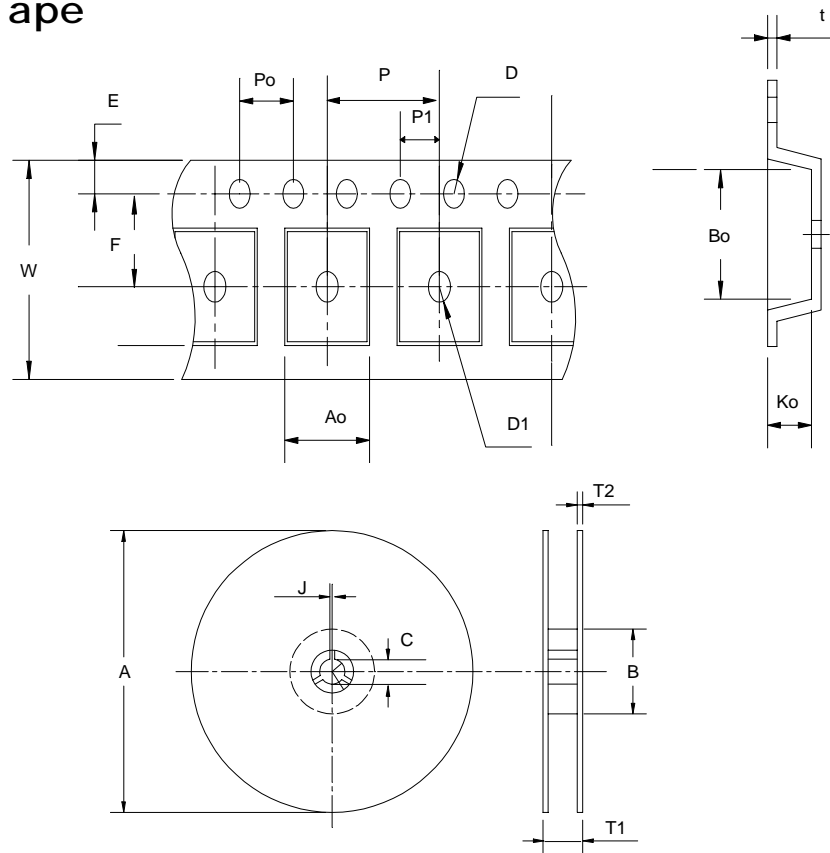

Application	A	B	D0	D1	E	F	P0	P1	P2
QSOP-16	6.95	5.4	1.55±0.05	1.55±0.1	1.75±0.1	5.5±0.05	4.0±0.1	8.0±0.1	2.0±0.05
	T	T2	W	W1	C1	C2	T1	T2	C
	0.3±0.05	2.2	12.0±0.3	9.5	13±0.3	21±0.8	13.5±0.5	2.0±0.2	80±1

(mm)

Customer Service

Anpec Electronics Corp.

Head Office :

5F, No. 2 Li-Hsin Road, SBIP,
Hsin-Chu, Taiwan, R.O.C.
Tel : 886-3-5642000
Fax : 886-3-5642050

Taipei Branch :

7F, No. 137, Lane 235, Pac Chiao Rd.,
Hsin Tien City, Taipei Hsien, Taiwan, R. O. C.
Tel : 886-2-89191368
Fax : 886-2-89191369